

Werkzeughalter-System Nakamura

Toolholder system Nakamura

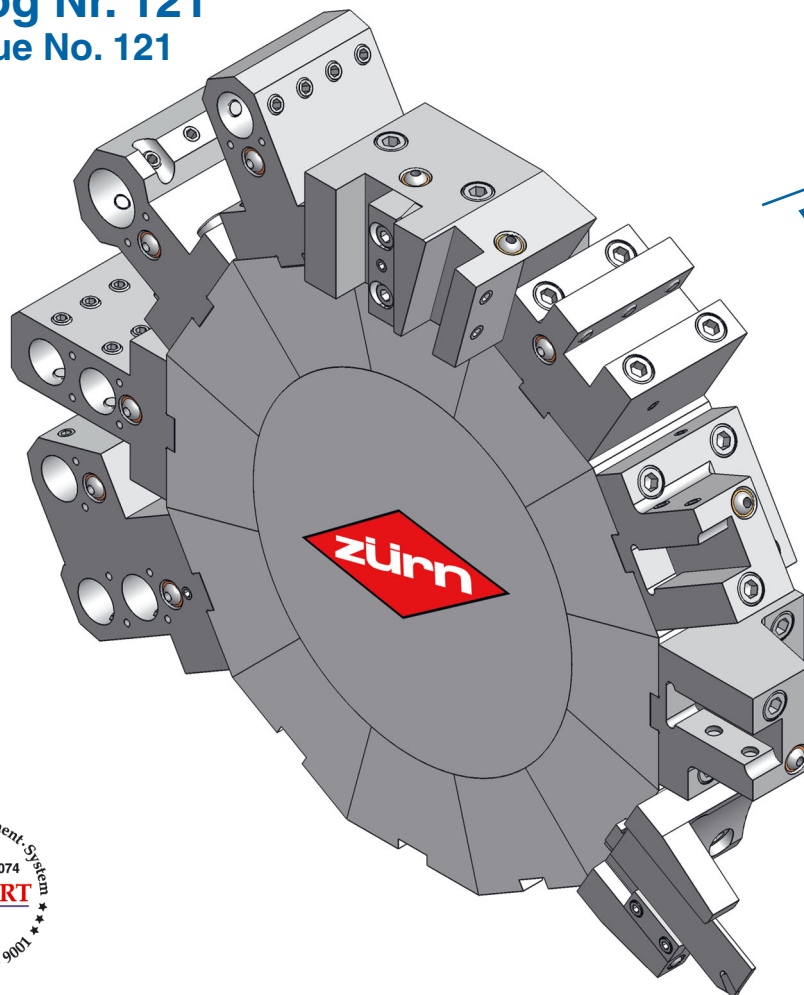

Preiskatalog Nr. 121 Price-catalogue No. 121



WT 100
WT 150



Drehhalter
Turning holder
WT 100-101

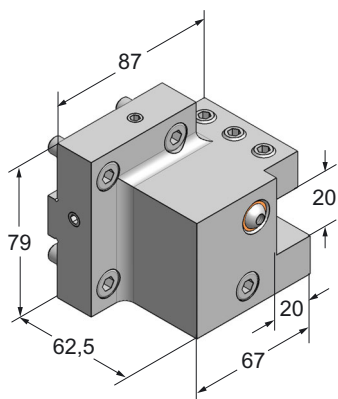

Drehhalter
Turning holder
WT 100-102

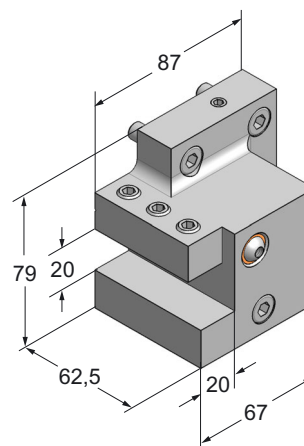

Art.-Nr.	Typ
WT 100-101	C 21410 / C 21411

Art.-Nr.	Typ
WT 100-102	C 21420 / C 21421

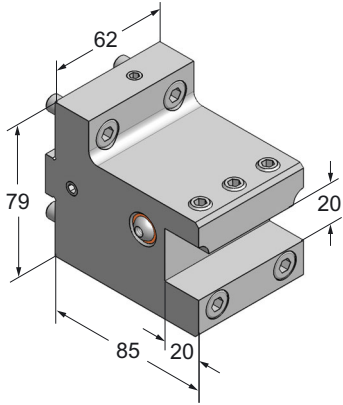
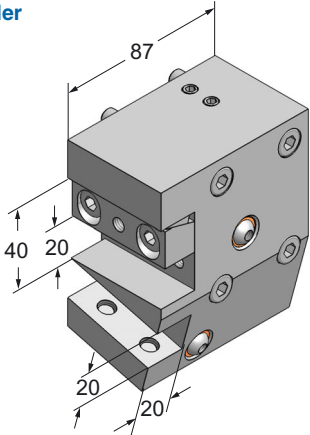
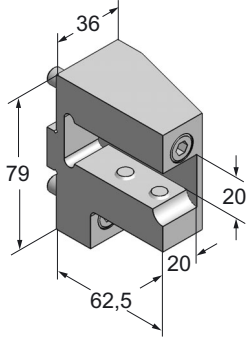
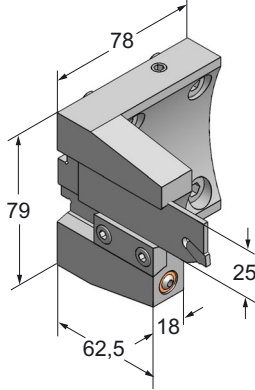
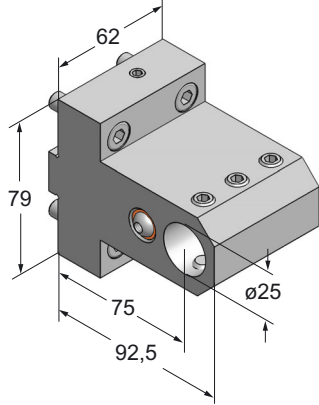
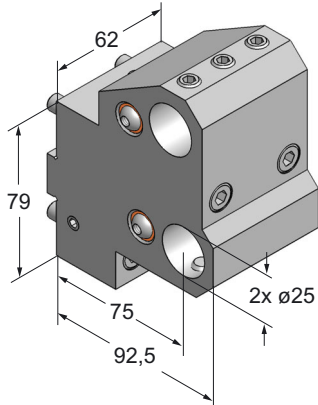

<p>Drehhalter Turning holder WT 100-103</p> 	<p>2-fach Drehhalter Multi turning holder WT 100-104</p> 
<p>Art.-Nr. Typ WT 100-103 Z 8415</p>	<p>Art.-Nr. Typ WT 100-104 C 21478 / C 21479</p>
<p>Abstechhalter Cut off toolholder WT 100-105</p> 	<p>Abstechhalter Cut off toolholder WT 100-108</p> 
<p>Art.-Nr. Typ WT 100-105 C 21430 / C 21431</p>	<p>Art.-Nr. Typ WT 100-108</p>
<p>Bohrstangenhalter Kühlmittel intern + extern Boring bar holder Coolant internal + external WT 100-113</p> 	<p>2-fach Bohrstangenhalter Kühlmittel intern + extern Multi boring bar holder Coolant internal + external WT 100-114</p> 
<p>Art.-Nr. Typ WT 100-113 C 22410 / C 22416</p>	<p>Art.-Nr. Typ WT 100-114 C 22412 / C 22413</p>

Drehhalter
Turning holder
WT 150-101

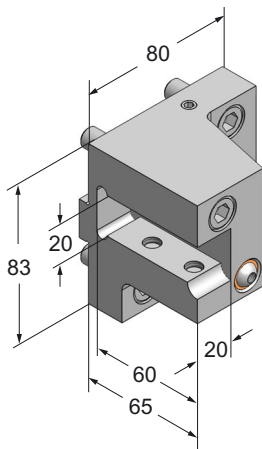

Drehhalter
Turning holder
WT 150-102

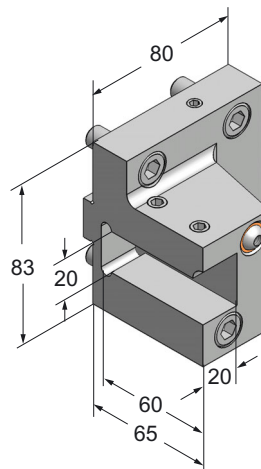

Art.-Nr.	Typ
WT 150-101	W 1431 / W 1441

Art.-Nr.	Typ
WT 150-102	W 1432 / W 1442

Drehhalter
Turning holder
WT 150-103

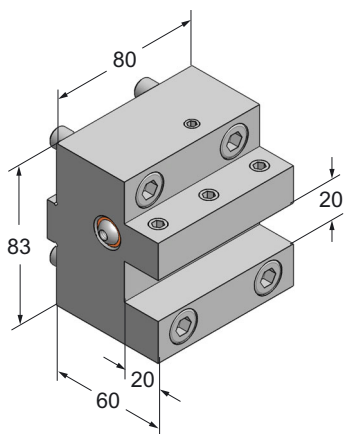

2-fach Drehhalter
Multi turning holder
WT 150-104

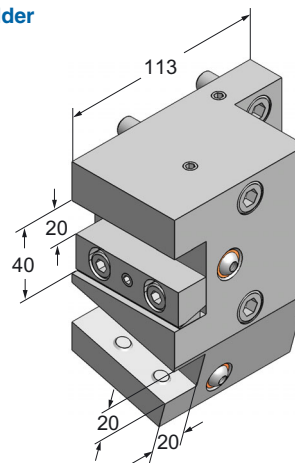

Art.-Nr.	Typ
WT 150-103	W 1415 / W 1425

Art.-Nr.	Typ
WT 150-104	R 1452

Abstechhalter
Cut off toolholder
WT 150-108

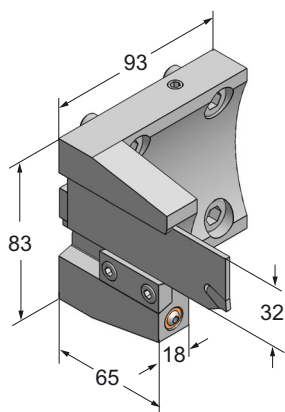

Art.-Nr.	Typ
WT 150-108	

Bohrstangenhalter Kühlmittel intern + extern
Boring bar holder Coolant internal + external

WT 150-112

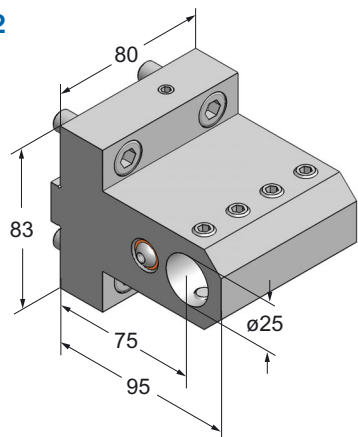

Bohrstangenhalter Kühlmittel intern + extern
Boring bar holder Coolant internal + external

WT 150-113

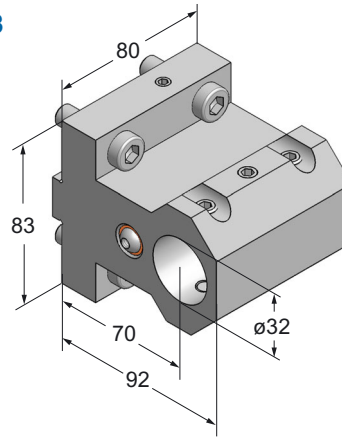

Art.-Nr.	Typ
WT 150-112	W 4437 / W 4447

Art.-Nr.	Typ
WT 150-113	Z 2417 / Z 2427

2-fach Bohrstangenhalter Kühlmittel intern + extern
Multi boring bar holder Coolant internal + external

WT 150-114

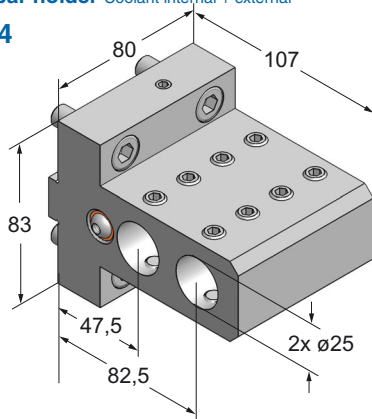

3-fach Bohrstangenhalter Kühlmittel intern + extern
Multi boring bar holder Coolant internal + external

WT 150-115

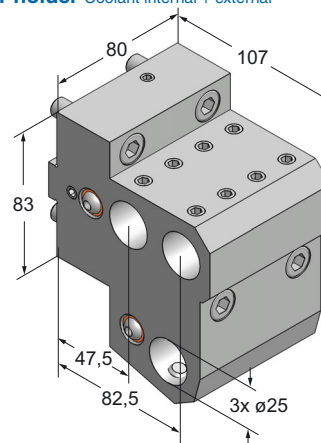

Art.-Nr.	Typ
WT 150-114	R 8418 / R 8428

Art.-Nr.	Typ
WT 150-115	R 8453 / R 8463

Preisstellung: ab Werk, ausschließlich MwSt. und Verpackung

Zahlung: 10 Tage 2% Skonto - 30 Tage rein netto

Pricing: ex works, packaging and transport insurance are not included

Payment: 30 days (net)